

Vertical mast lifts

Star 10

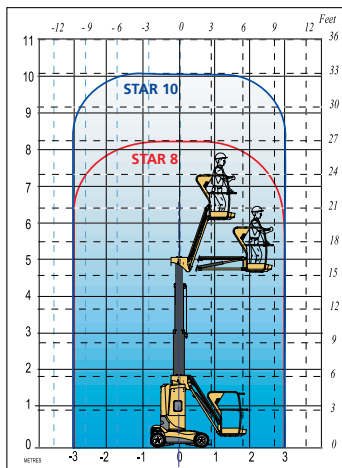
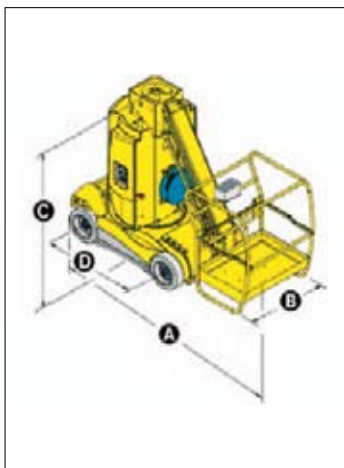

SPECIFICATIONS

| | Star 10 |
|------------------------|----------------------------------|
| Working Height | 10 m / 32 ft 10 in |
| Platform Height | 8 m / 26 ft 3 in |
| Horizontal outreach | 3,1m / 10 ft 2 in |
| Platform Capacity | 200 kg / 441 lb |
| A Length | 2,65m / 8 ft 8 in |
| B Width | 0.99m / 3ft 2in |
| C Stowed Height | 1.99 m / 6 ft 6 in |
| D Wheelbase | 1.2 m / 3 ft 11 in |
| Ground Clearance | de 2,5 cm à 10 cm / 1 in to 4 in |
| Platform size | 0.92x0.68m / 36 in x 27 in |
| Tailswing | 0 |
| Drive speed | 0.7 - 4.5 km/h / 0.43 - 2.8 mph |
| Outside turning radius | 1.87m / 6ft 1 in |
| Turntable rotation | 345° |
| Traction batteries | 24 V (2 x 12 V) / 240 Ah |
| Gradeability | 23% |
| Tilt alarm | 3° |
| Non marking tyres | 16" x 5" x 10,5" |
| Weight | 2760 kg / 6085 lb |